

inspec.x L 5.6/105 VIS-NIR 1x

for large format high-resolution sensors optimized for VIS and NIR sensitivity



The new VIS-NIR lens series from Excelitas sets standards in the field of visual and non-visual inspection. Developed for long line and large area sensors, it offers an incredibly good apochromatic design. Ultra-sharp and high-contrast images can be created at a wide range of different wavelengths from 400 to 1150nm without having to refocus. The diffraction-limited design impresses with extreme performance across the entire object field, so that optimal results can also be achieved at the edges.

Your Benefits

- VIS-NIR scan without refocus
- Apochromatically corrected lens from 400 to 1150nm
- Diffraction limited design
- Ultra high resolution for large area and line sensors
- Great price performance ratio

The new inspec.x VIS-NIR series comes with four different lenses that are optimized for different magnifications and are equipped with the established V-groove interface.

Every version of this new series matches the Excelitas Modular Focus System and scores with flexibility and modularity.

Applications

- PCB inspection
- Print inspection
- Surface inspection
- Waste inspection
- Battery inspection
- Food inspection

LINOS

Key Features

- No refocusing across VIS and NIR range (apochromatic correction for 400-1150nm)
- Perfect match with 5µm Pixel size
- Flexible mounting system for almost any image processing camera
- Full metal barrel with lockable aperture

Mechanical accessories, including helical focus mounts, adapters and extension tubes are described @ excelitas.com/product/linos-machine-vision-accessories



Specifications

Part No.	0703-082-000-30
focal length [mm]	105.4
f-stop	5.6
f-stop range	5.6 ... 22
f-stop lockable	yes, locking screw
Numerical aperture (object/image)	0.09/0.09
Image circle max. [mm]	82
Magnification optimized	1
Rec. magnification range	0.85 ... 1.2
Rec. working distance [mm]	153 ... 190
Spectral range [nm]	400 - 1150
Azimuth marked	yes
Interface	V-groove ø46h7
Filter thread	M43 x 0.75
Lenght [mm]	72.5
Diameter [mm]	61.4
Weight [g]	370
Storage temperature [°C]	-25 ... +70
Working temperature [°C]	0 ... +50
Optical number	7608-9011
Sensor cover glass (included)	0.76mm D263

Optical data

Part No.		0703-082-000-30	
SF [mm]	-71.4		
S'F' *) [mm]	71.4		
HH' *) [mm]	-7.5		
SH *) [mm]	34.0		
S'H' [mm]	-34.0		
SEnP [mm]	34.1		
S'Exp *) [mm]	-34.0		
f-stop	ø EnP	ø ExP	
5.6	18.8	18.8	
8	13.2	13.2	
11	9.6	9.6	
16	6.6	6.6	
22	4.8	4.8	

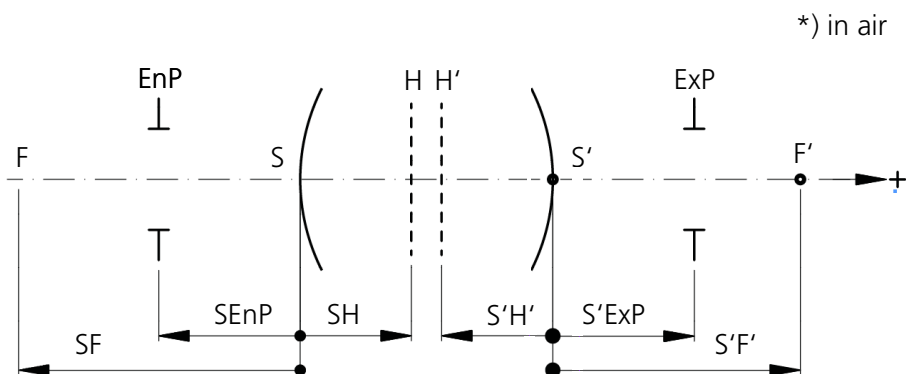

Dimensions

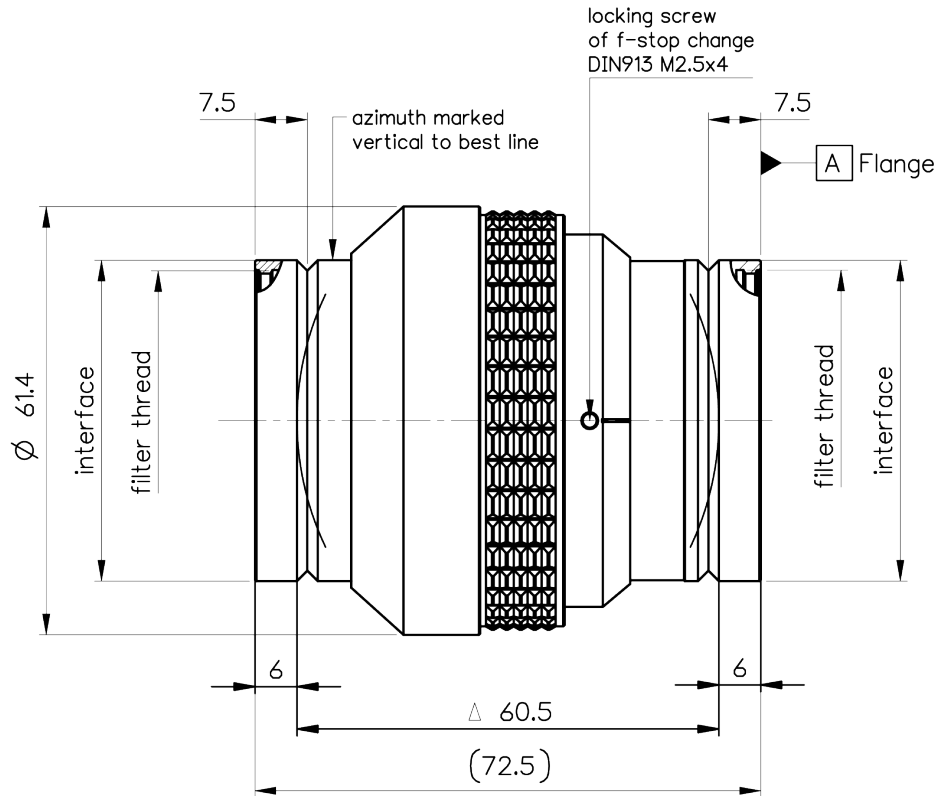

For further information about our Inspec.x L series, please scan or click the QR-Code.



Optical Performance

MTF at ratio 1x f/5.6

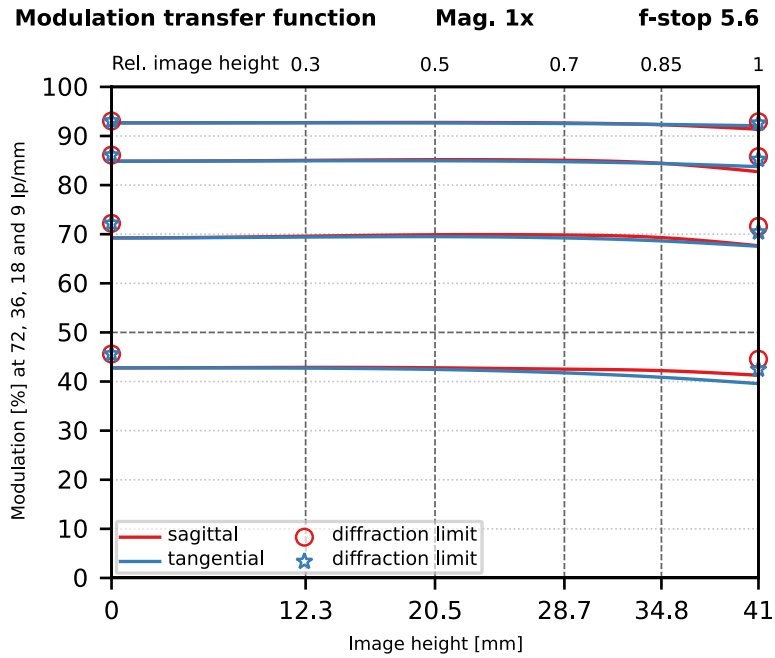

MTF at ratio 1x f/8.0

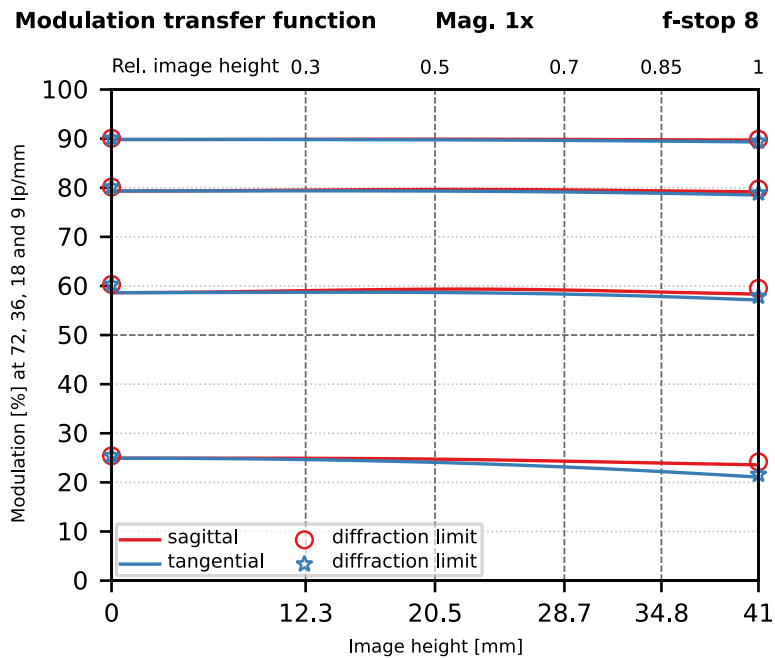

All spatial frequencies [lp/mm], image heights [mm] and magnifications are related to sensor side.

Fall-off in illumination Mag. 1x

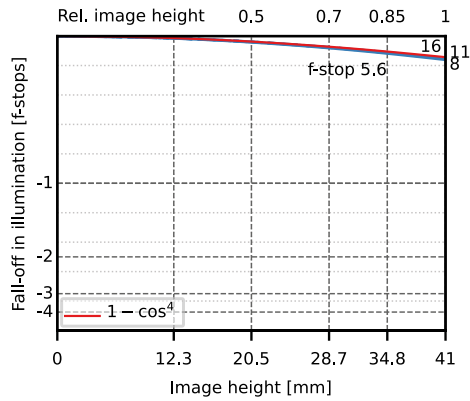

Distortion Mag. 0.85x ... 1.2x

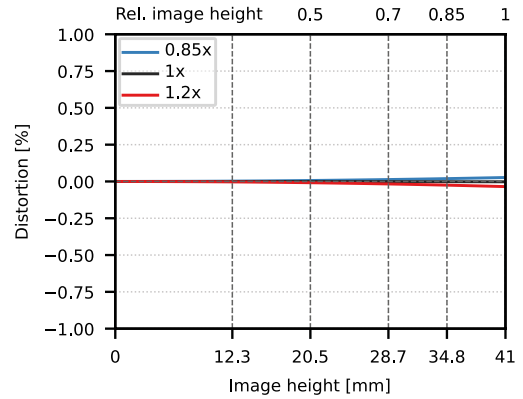

Long. chrom. aberration Mag. 1x

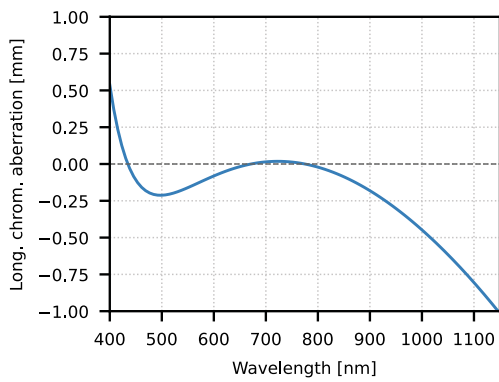

Transmission - inspec.x L 5.6/105 VIS/NIR 1x

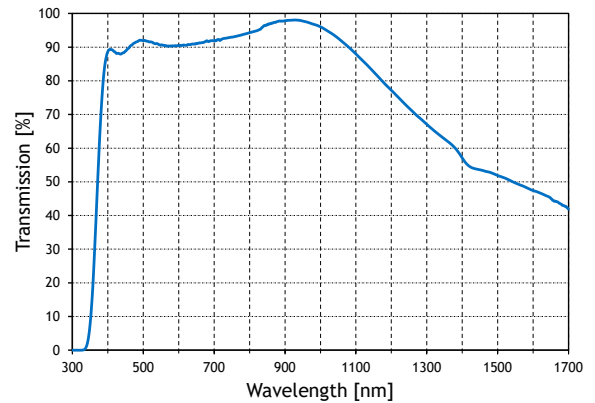

All spatial frequencies [lp/mm], image heights [mm] and magnifications are related to sensor side.

MachVis

Lens Selection and Configurator Software

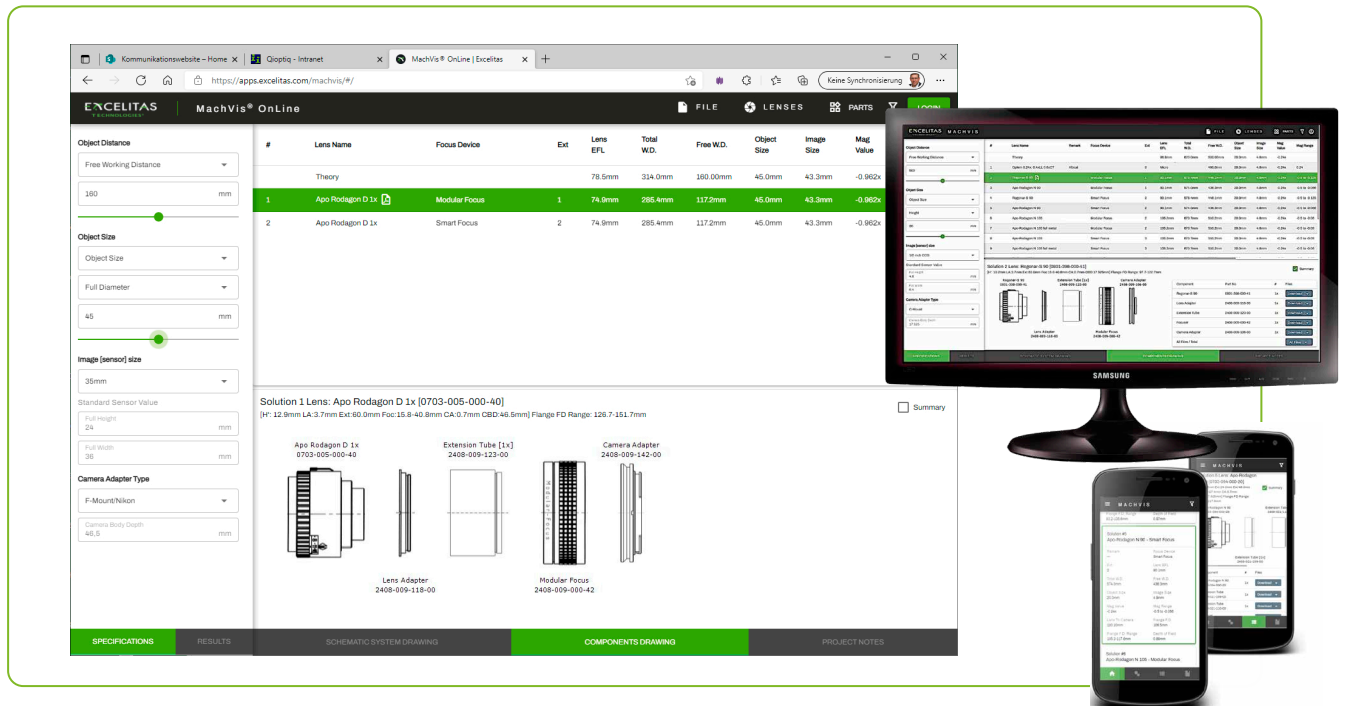

MachVis:
Access for FREE!



For further information about our Lens Selection Software MachVis, please scan or click the QR-Code.

Europe
+49 (0) 89 255 458 0

North America
+1 (800) 429 0257

Asia/Pacific
+65 64 99 7777

Inspection@excelitas.com
www.qioptiq-shop.com

www.excelitas.com